



CBD-3333-6M 3/4/HE

Code: 1009171



Double inlet centrifugal fans with direct drive motors and forward curved impeller

Fan:

- Galvanised steel sheet casing.
- Forward curved impeller in galvanised sheet steel.
- Supplied with PSB support feet.

Motor:

- High efficiency (HE) motors in compliance with ErP 2015.
- Enclosed motors with built-in thermal protector, class F, with ball bearings, IP54 protection.
- Single-phase 220-240 V 50 Hz and three-phase 220-240/380-415 V 50 Hz.
- Working temperature: -25 °C +60 °C.

Finish:

- Galvanised steel sheet.



CHARACTERISTIC CURVE AND ACOUSTICS AT 1.2KG/M³

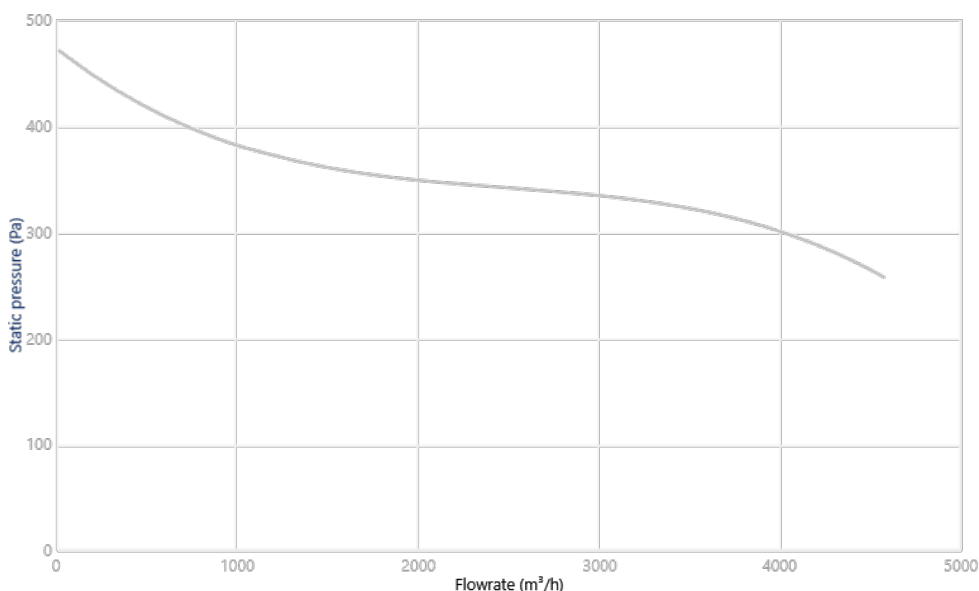

Design Point

Q (m³/h)	
Ps (Pa)	

Service Point (SP)

Q (m³/h)	-
Ps (Pa)	-
Pd (Pa)	-
Pt (Pa)	-

Acoustics: Radiated, 3 (m), Free field

The values given are obtained under laboratory conditions according to ISO 3744.

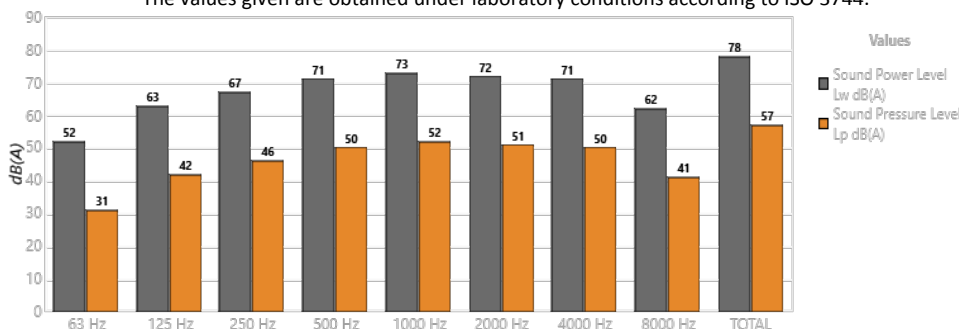

Band	Lw dB(A)	Lp dB(A)
63 Hz	52	31
125 Hz	63	42
250 Hz	67	46
500 Hz	71	50
1000 Hz	73	52
2000 Hz	72	51
4000 Hz	71	50
8000 Hz	62	41
TOTAL	78	57

TECHNICAL CHARACTERISTICS

Airflow maximum (m³/h)	4580
Speed (rpm)	850
Maximum static pressure (Pa)	471.1
Maximum total pressure (Pa)	471.1



ERP

Efficiency	40.4%
Efficiency grade N	47.7
Measurement category	A
Efficiency category	Static
Specific ratio	1.00
Flowrate (m ³ /h)	3057

Pressure (Pa)	332
Input power (kW)	0.699
Speed (rpm)	932
Variable speed drive	VSD not necessary
ErP compliance	2015

♦ Data established at point of optimum efficiency

MOTOR DATA

Rated Mechanical Power (kW)	0.55
Hz/phases	50/1
Motor (rpm)	850

Poles	6P
Max. current (A) 220-240 V	4.3
Motor frame size	90

Data can change, please check motor plate

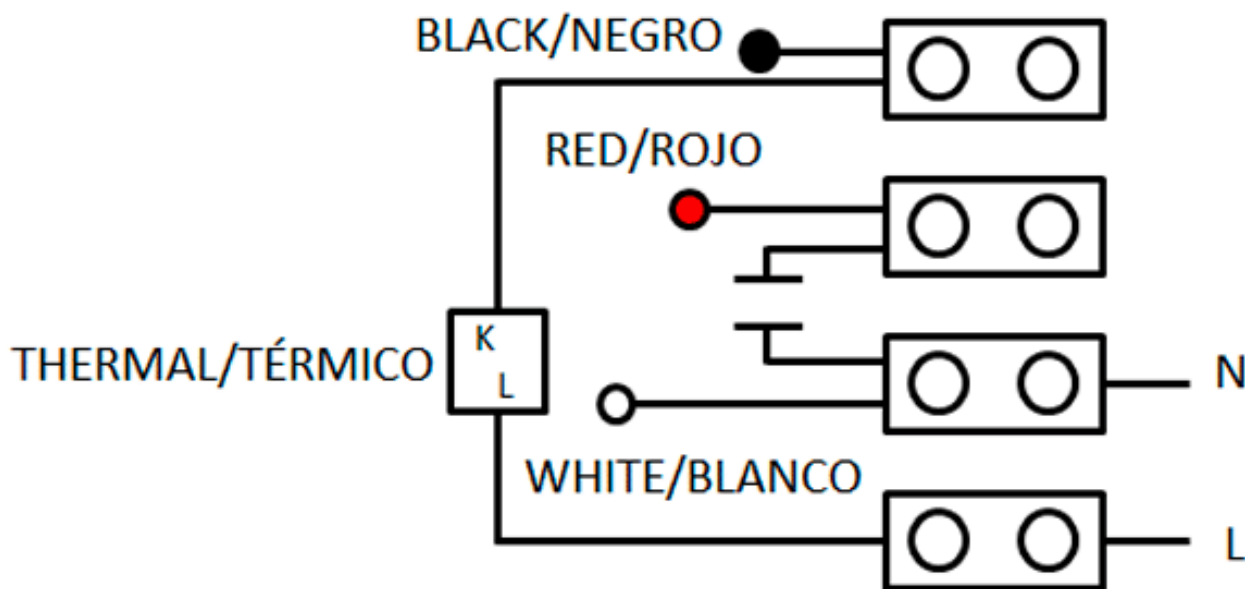

DIMENSIONS

A	B1	B2	E	E1	H	K	L	UxS	V	X	Z1	Z
493	526	290	230	82	236	387	345	9x16	390	415	70	457

Dimensions without explicitly defined units are shown in millimeters (mm). Dimensions depending on the motor are approximate

Approx. weight (kg)	23
---------------------	----

