



# CBD-2828-6M 1/3/HE

Code: 1009167



## Double inlet centrifugal fans with direct drive motors and forward curved impeller

### Fan:

- Galvanised steel sheet casing.
- Forward curved impeller in galvanised sheet steel.
- Supplied with PSB support feet.

### Motor:

- High efficiency (HE) motors in compliance with ErP 2015.
- Enclosed motors with built-in thermal protector, class F, with ball bearings, IP54 protection.
- Single-phase 220-240 V 50 Hz and three-phase 220-240/380-415 V 50 Hz.
- Working temperature: -25 °C +60 °C.

### Finish:

- Galvanised steel sheet.



## CHARACTERISTIC CURVE AND ACOUSTICS AT 1.2KG/M<sup>3</sup>

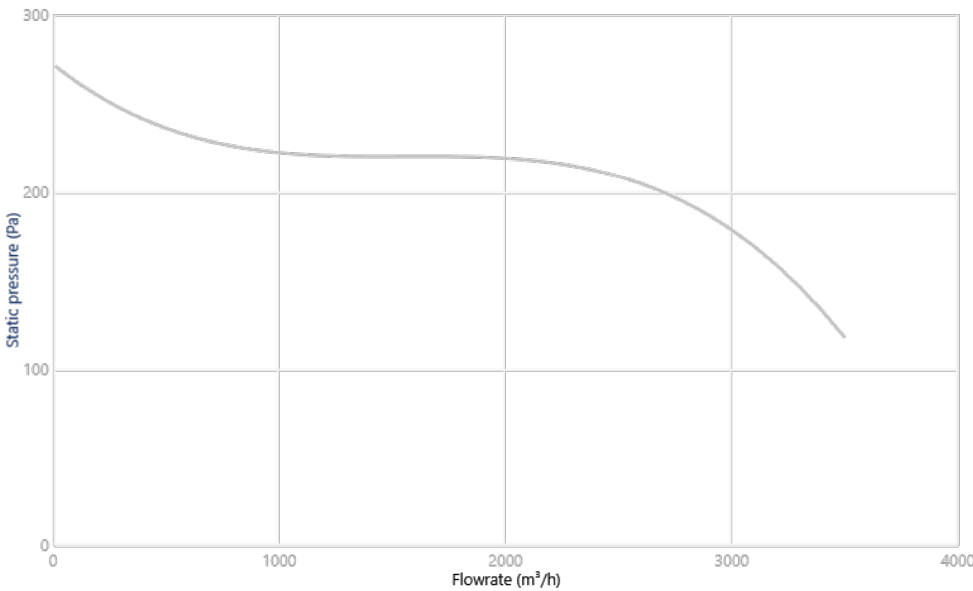

### Design Point

Q (m³/h)	
Ps (Pa)	

### Service Point (SP)

Q (m³/h)	-
Ps (Pa)	-
Pd (Pa)	-
Pt (Pa)	-

Acoustics: Radiated, 3 (m), Free field

The values given are obtained under laboratory conditions according to ISO 3744.

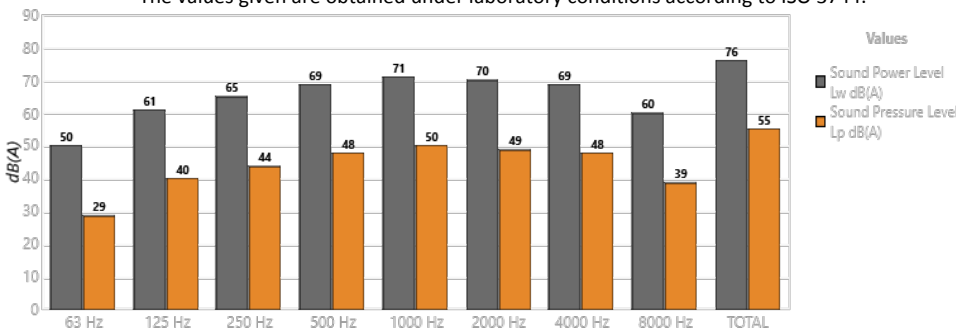

Band	Lw dB(A)	Lp dB(A)
63 Hz	50	29
125 Hz	61	40
250 Hz	65	44
500 Hz	69	48
1000 Hz	71	50
2000 Hz	70	49
4000 Hz	69	48
8000 Hz	60	39
TOTAL	76	55

## TECHNICAL CHARACTERISTICS

Airflow maximum (m³/h)	3500
Speed (rpm)	830
Maximum static pressure (Pa)	270.8
Maximum total pressure (Pa)	270.8



ERP

Efficiency	37.6%
Efficiency grade N	46.7
Measurement category	A
Efficiency category	Static
Specific ratio	1.00
Flowrate (m <sup>3</sup> /h)	2336

Pressure (Pa)	213
Input power (kW)	0.368
Speed (rpm)	947
Variable speed drive	VSD not necessary
ErP compliance	2015

♦ Data established at point of optimum efficiency

MOTOR DATA

Rated Mechanical Power (kW)	0.25
Hz/phases	50/1
Motor (rpm)	830

Poles	6P
Max. current (A) 220-240 V	2.2
Motor frame size	80

Data can change, please check motor plate

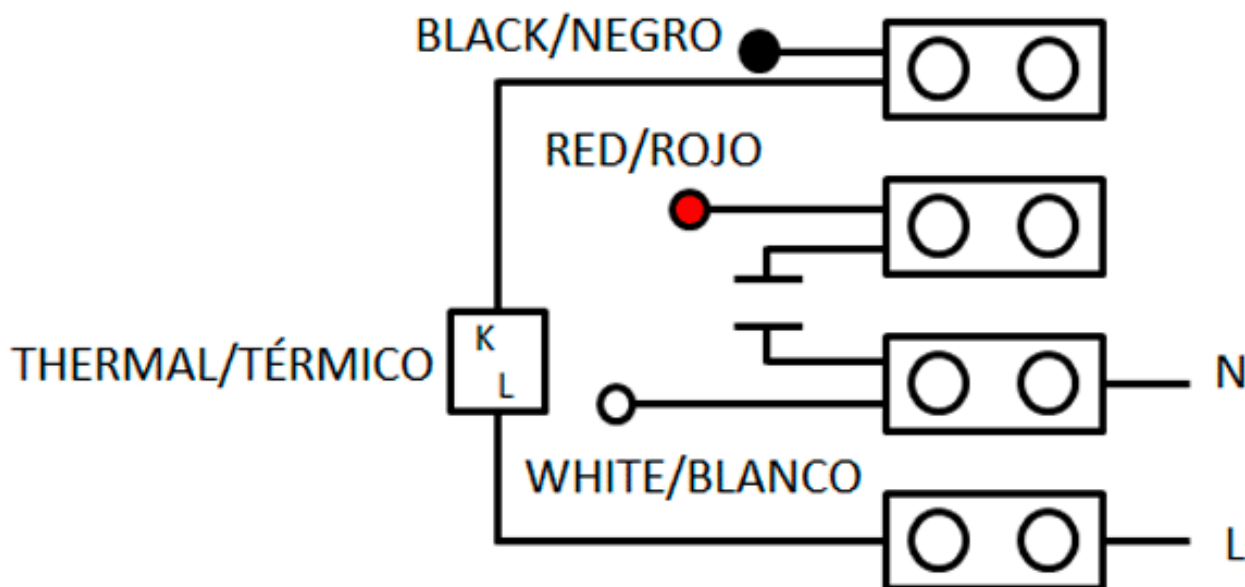

DIMENSIONS

A	B1	B2	E	E1	H	K	L	UxS	V	X	Z1	Z
422	450	246	202	73	204	326	292	9x16	315	352	45	371

Dimensions without explicitly defined units are shown in millimeters (mm). Dimensions depending on the motor are approximate

Approx. weight (kg)	15.2
---------------------	------

